



How to cite this article:

Hanafi, Y., Murtadho, N., Hassan, A. R., Saefi, M., Ikhsan, M. A., & Nur Diyana, T. (2021). Self-regulation in Qur'an learning. *Malaysian Journal of Learning and Instruction*, 18(2), 103-128. <https://doi.org/10.32890/mjli2021.18.2.4>

## **SELF-REGULATION IN QUR'AN LEARNING**

**<sup>1</sup>Yusuf Hanafi, <sup>2</sup>Nurul Murtadho, <sup>3</sup>Abd Rauf Hassan,  
<sup>4</sup>Muhammad Saefi,  
<sup>5</sup>M. Alifudin Ikhsan & <sup>6</sup>Tsania Nur Diyana**

<sup>1&2</sup>Faculty of Letters

Universitas Negeri Malang, Malang, Indonesia

<sup>3</sup>Fakulti Bahasa Modern dan Komunikasi

Universiti Putra Malaysia, Selangor, Malaysia

<sup>4,5&6</sup>Postgraduate School, Universitas Negeri Malang,  
Malang, Indonesia

*<sup>1</sup>Corresponding author: [yusuf.hanafi.fs@um.ac.id](mailto:yusuf.hanafi.fs@um.ac.id)*

Received: 30/10/2019   Revised: 6/10/2020   Accepted: 5/1/2021   Published: 31/7/2021

### **ABSTRACT**

**Purpose** - The emergence of academic anxiety and poor learning outcomes among Indonesian first-year students at higher education institutions emphasized the need to measure the level of self-regulated learning (SRL). This study was part of a larger SRL research project in the area of learning Qur'an recitation, where we attempted to explore further on how students applied SRL. By using a new perspective of SRL as a social process that emphasized interaction, we investigated how the situated environment influenced learning.

**Method** - Quantitative and qualitative approaches were applied. A set of questionnaires generated from the adaptation process was successfully validated through rigorous psychometric testing. A total of 420 first-year students responded to the questionnaire. Then semi-structured observations and interviews were conducted among eight students. Finally, data obtained from observation checklists and interviews were triangulated.

**Findings** - The SRL level for first-year students in learning Qur'an recitation was insufficient, with a score of 3.37 out of 5.00. The highest score on the Meta-Affective dimension was  $M = 3.64$ , and the lowest score on the Sociocultural-Interactive dimension was  $M = 2.98$ . These results indicated that although anxiety was not a serious problem, yet it was still an obstacle for some students with low SRL to achieve targeted learning goals. Furthermore, these students did not have the awareness to seek help for their learning difficulties. This situation was further aggravated by the lack of assistance from instructors in creating conducive learning environments for students to interact with each other.

**Significance:** The standard deviations on all SRL dimensions identified in this study were high, showing a large gap between students who had high and low SRL. This condition requires instructors to provide significant assistance. We suggest heterogeneous grouping to enable more intensive interactions between students to increase the sociocultural-interactive dimension. We believe that seamless interaction is the most tangible support for promoting SRL.

**Keywords:** Self-regulation learning, Qur'anic language, Qur'anic recitation, validation studies.

## INTRODUCTION

Currently, learning is seen as an active and constructive process, where students are required to be active agents of their learning process (Pape et al., 2003). Students must have self-regulated learning (SRL), in which they can plan, monitor, and reflect on their cognition, behaviour, and emotions to achieve learning goals (Pintrich, 2000; Zimmerman, 2000). By becoming more independent, students will adapt their skills and knowledge to new conditions, moving from one learning context to another (Boekaerts, 1999). In another sense, SRL is the key to success for first-year students facing the challenges of

transitioning to university studies (Christie et al., 2013; Koivuniemi et al., 2017; Panadero, 2017).

Upon enrolling in universities, first-year students encounter a sense of academic anxiety (Peng, 2012). The idea that they have limitations in balancing their learning with life can have an impact on their learning outcomes (Huie et al., 2014). In the context of this study, we highlighted the results of learning Qur'an recitation among first-year students who had not yet reached satisfactory levels (Hanafi et al., 2019). In another report, it was found that the application of active learning and the provision of integrated technology support did not guarantee that students would achieve the expected learning outcomes of Qur'an recitation (Hanafi et al., 2019). This meant that application of the student-centered approach in Qur'an recitation class did not succeed in promoting student SRL to an adequate level. Poor learning outcomes were very likely related to SRL, which was relatively low (Knouse et al., 2014; Thibodeaux et al., 2017).

Some of the students seemed to have low interest and motivation because they felt that they did not have the necessary adequate skills to attend Qur'an recitation class (Hanafi et al., 2019). In reading classes, which were included in the meta-affective (MA) dimension, learning interests were considered more important than the cognitive (C) and metacognitive (MC) dimensions (Mason, 2004). They proved to be positively correlated with the application of the SRL strategy (McWhaw & Abrami, 2001). Of the various SRL models proposed by theorists, some provided focus and emphasis on the role of motivation, such as the framework proposed by Pintrich (1999) and Boekaerts (1997), and almost all of them stated that motivation was a critical factor in academic success (Pintrich & de Groot, 1990; Zimmerman et al., 1992). Several literature reviews and studies had strengthened our resolve that the lack of interest and motivation, and the poor learning outcomes of students, indicated that they could not use SRL strategies in learning Qur'an recitation.

Although learning recitation is an important and distinctive part of the Qur'an because it is related to Tajweed knowledge, students' cognitive and meta-cognitive dimensions seemed to be sidelined in SRL (Mason, 2004) in the context of Qur'an learning research. Students' cognitive learning strategy(s) can affect the motivation and persistence of student behaviour which is related to achievement, meaning that the cognitive dimension plays a vital role in controlling critical learning (Schunk, 1989). Pintrich and de Groot (1990) emphasized that cognitive

learning strategy dimensions were fundamental SRL elements for quality learning outcomes. The results of research conducted by Oi et al. (2015) showed that students who were high-achievers tended to use cognitive learning strategies, such as connecting knowledge with learning material. In the context of this research, the question is how do students apply Tajweed knowledge in improving the quality of their recitation. Reading fluency is closely related to adherence to the rules of recitation or Tajweed (Zarif et al., 2014). This explanation showed that students with low Tajweed knowledge tended to have low learning motivation, which in turn, impacted the quality of their learning outcomes which were unsatisfactory (Hanafi et al., 2020; Hanafi et al., 2019). This clearly indicated that Tajweed knowledge had an impact on SRL.

Although some have very good self-regulation; we realize that not all first-year students have the ability of self-regulation (Lindblom-Ylänne et al., 2017). Therefore, it is necessary to determine which students have low SRL so as to provide the external support needed. An excellent understanding of SRL capacity will help students achieve their targeted abilities, especially in attending Qur'an recitation classes that are not only related to learning to read (Harding et al., 2019; Morshedian et al., 2017), but also in learning Arabic (Liu & Lee, 2015).

The main obstacle faced is that there is no reliable instrument for measuring student SRL in the context of learning Qur'an recitation. In this study, we chose the adaptation of the SRL questionnaire in foreign language learning developed by Habók and Magyar (2018). This choice was based on two considerations. Apart from the time taken to create a new one, this questionnaire had similar characteristics, namely self-regulation in foreign language learning. Despite this, since the context is different because the word of God is different from the word of man, the questionnaire was validated using rigorous psychometric testing. The validated questionnaire was also expected to contribute to the development of a reliable SRL measurement instrument in the context of Qur'an recitation.

In this study, the first objective was to identify the SRL dimensions in the questionnaire as a basis for measuring how students applied SRL in a Qur'an recitation task. For the second objective, we used quantitative methods to show the students' SRL level using a validated questionnaire, which was then followed by a qualitative method to test how the students organized their own learning by way of interview

and observation techniques. Based on a combination of sociocultural-interactive (SI) and meta-sociocultural-interactive (MSI) dimensions, this study offers a new perspective on the conceptualization of SRL, which is perceived as a social process that emphasizes interaction (Hadwin et al., 2018; Usher & Schunk, 2018). This perspective will reveal how little attention has been paid by instructors to promote SRL students, and how support provided by the environment is needed through emphasis on interaction. Based on our knowledge, this topic is relatively underexplored (Alvi & Gillies, 2015, 2020).

## **METHODOLOGY**

### **Quantitative Approach**

This study involved 420 undergraduate students (hereafter, participants) from the State University of Malang (UM), Indonesia, to complete the questionnaire. They were first-year students aged between 19 and 21 years who were required to attend a Qur'an recitation training programme for the 2018/2019 school year. The participants were divided into groups in two phases. Each phase of 250 students was asked to complete 19 questionnaire items. In phase one, 200 questionnaires were returned, with a response level of 80.00 percent. In phase two, 220 questionnaires were returned, with a response level of 88.00 percent. The number of participants in this study was sufficient for the minimum benchmark sample for factor analysis according to Dörnyei (2003) and Tabachnick and Fidell (2007).

We adapted Habók and Magyar's (2018) 34-item Self-Regulated Foreign Language Learning Strategy Questionnaire (SRFLLSQ) to collect original questionnaire items. In this adaptation, the original English version of the SRFLLSQ questionnaire was translated into Indonesian. Since we had difficulty finding translators fluent in English and Indonesian, we could not use Brislin's Back-translation model (Brislin, 1970). Instead, we applied a combined technique as applied by Cha et al. (2007). This adaptation was based on the meaning of items that fit the characteristics of Qur'an recitation learning, but not literally. Two instructors teaching Qur'an recitation and four professional academics in the fields of Language Education, Islamic Religious Education, and Educational Psychology were involved in reviewing and checking the equivalence of the original, the translated questionnaire contents, and its compatibility with the characteristics of Qur'an recitation learning. Each of the professional academics ranked the items according to a choice of "yes" or "no".

Questionnaire items were retained if a minimum of four validators agreed that the items were appropriate to measure student SRL in learning Qur'an recitation. As a result of this content equality validation process, 19 items were retained. Finally, the Self-Regulated Qur'anic Learning (SRQL) questionnaire, was administered to five students as potential respondents to ensure that they completely understood the questionnaire statement.

To uncover the dimensions of the SRQL questionnaire, we conducted many analyses, including item analysis, Exploratory Factor Analysis (EFA), Confirmatory Factor Analysis (CFA), and internal consistency test on the SRQL questionnaire. Item analysis included descriptive analysis (mean and standard deviation) and the calculation of correlations between total scores with each item using Pearson correlation. The item would be retained if it did not reach 2.50 SD from the mean and with a p-value of less than 0.05 (significance).

In phase one, EFA through Principal Components Analysis (PCA) with varimax rotation was conducted to empirically explore the dimensions that underlie the SRQL questionnaire. The Bartlett sphericity test and KMO index were also calculated to determine the adequacy of the sample used in factor analysis. Eigenvalue > 1.00 was used as the threshold to determine the number of new dimensions (Kaiser, 1970). EFA was carried out until the cleanest factor structure was achieved, i.e. all items had a loading factor of more than 0.50, no cross-loading items, and there were at least two items in each dimension.

In phase two, after the cleanest factor structure was achieved with EFA, a CFA was carried out to confirm the EFA results. The first-order model was obtained from the EFA, then the correlated model was examined, followed by a second-order model, the hierarchical model, to verify whether all dimensions are part of one large dimension, namely SRQL. CFA was conducted with maximum likelihood estimation because it was suitable for non-normality problems (Maydeu-Olivares et al., 2017). The fit model was evaluated using the Chi-Square Goodness of Fit Test ( $\chi^2 / df$ ), standardized root mean square residual (SRMR), the root mean square error of approximation (RMSEA), comparative fit index (CFI), the goodness of fit index (GFI), and the Tucker-Lewis index (TLI). Finally, internal consistency was evaluated by calculating Cronbach's Alpha ( $\alpha$ ), Construct Reliability (CR), Average Variance Extracted (AVE), and concurrent validity. Meanwhile, to uncover the level of students' self-regulated learning in Qur'an recitation, we conducted a descriptive statistical test to show the average scores and

standard deviations of participants in each dimension and total score of SRQL.

### **Qualitative Approach**

We observed and interviewed eight students, consisting of four students with low SRL (L1-L4 code) and four students with high SRL (H1-H4 code). The participants were selected using purposive sampling technique, assuming that those with low SRL tended to have poor learning outcomes. Simultaneously to confirm this statement, the four L1-L4 students who were observed were those in the low ability group, and the four H1-H4 students were students in the high ability group. Observations and interviews were conducted after the quantitative study was concluded.

Before commencing with the observation, a checklist was prepared by following the logic of a quantitative research questionnaire. This study used a think-aloud approach to follow the students' SRL process. The focus of observation was how learning was enacted. The observation was carried out for approximately 1 hour 30 minutes per the semester hours of Qur'an recitation learning at UM campus. The researchers did not interfere in the learning process during the observation. Interviews were conducted after the students completed their learning. The purpose of the interview was to tick off the points in the checklist while clarifying how they thought when answering specific questions on the quantitative research questionnaire. The interview lasted about an hour.

We used methodological triangulation to complement the quantitative data from the survey, via observations and interviews. As this research method emphasized quantitative processing, we attempted to complement the results with broader findings and thus the results were evaluated qualitatively. Therefore, we used methodological triangulation to measure the students' SRL levels in Qur'an recitation learning in three dimensions: students' SRL levels, students' opinions and perspectives about their SRL, and data on the learning process.

Several strategies were implemented based on the explanation mentioned in order that the qualitative data obtained was reliable (Korstjens & Moser, 2018) in maintaining credibility. First, we focused the interviews on groups that had low and high SRL shown during continuous observations. Next, observations were conducted throughout the learning process to fulfil the prolonged engagement

aspect. After that, we also triangulated the data, and performed triangulation of researchers among principal investigators to authenticate analysis and interpretation. Finally, we checked the research results of the respondents to ensure accuracy of the data.

## **RESULTS**

### **Quantitative Findings**

The item analysis showed that the average item ranged from 2.76 to 4.22 (SD ranged from 0.77 to 1.12), with R-values in the range of 0.39 to 0.61. The results showed that 19 items were sufficient to be maintained because they met three criteria: the item did not exceed 2.50 SD of the mean, had a significant correlation ( $p < 0.01$ ), and the R-value did not exceed 0.80.

In phase one, which was carried out with EFA, we checked the adequacy of the sample first. The evaluation results with KMO = 0.80 showed that the sample was significant (Kaiser, 1970). The results of Bartlett's test of sphericity also showed good correlation between items that were strong enough to do EFAs and multi-variate normally distributed data with Chi-square,  $\chi^2(171) = 951.93$ ,  $p < 0.01$ .

PCA with varimax rotation performed on 19 items of the SRQL questionnaire showed five dimensions produced with a total variance of 59.20 percent. Kline (1994) explained that these results were very good for social science research. Items with factor loading below 0.50 would be deleted, and two items were deleted, namely MSI5 and MA4. From the results of the cleanest factor structure produced, 17 items-5 dimensions were produced. The meta-sociocultural interactive (MSI) dimension consisted of four items with an eigenvalue of 5.00 and (%) of the variance of 26.31. The meta-cognitive dimension (MC) also consisted of five items with an eigenvalue of 2.37 and (%) of the variance of 12.49. The sociocultural-interactive (SI) dimension consisted of three items with an eigenvalue of 1.57 and (%) of the variance of 8.28. The cognitive dimension (C) consisted of two items with an eigenvalue of 1.23 and (%) of the variance of 6.47. The meta-affective (MA) dimension consisted of three items with an eigenvalue of 1.07 and (%) of the variance of 5.64.

In phase two, the 17 items-5 dimensions produced from EFA were validated through CFA using different samples. The results of the validation with correlated models showed a fairly good match with



the Chi-square value ( $\chi^2 / df$ ) = 2.00, SRMR = 0.05, RMSEA = 0.06, CFI = 0.89, GFI = 0.90, and TLI = 0.86. An examination of the estimated Standardized Regression Weights ( $\lambda$ ) showed that there were three items that had a value of  $\lambda$  less than 0.50, namely MC3, MC5, and MA4. These three items were then deleted to obtain a better model match. The results of re-validation (Fig. 1) showed better compatibility with Chi-square values ( $\chi^2 / df$ ) = 1.74, SRMR = 0.05, RMSEA = 0.06, CFI = 0.94, GFI = 0.93, and TLI = 0.92. Furthermore, validation with the hierarchical model also showed a good match with the Chi-square value ( $\chi^2 / df$ ) = 1.82, SRMR = 0.05, RMSEA = 0.06, CFI = 0.93, GFI = 0.93, and TLI = 0.91. The CFA results showed that the data were in accordance with the model of the original instrument developed by Habók and Magyar (2018). All questionnaire items had a value of  $\lambda$  and a factor loading above 0.50, indicating that the observed variables were strong enough to reflect the construct variables (Tabachnick & Fidell, 2007).

A check on the internal consistency showed that the value of Cronbach alpha ( $\alpha$ ) ranged from 0.60 to 0.73, with  $\alpha$  overall items of 0.84, which was quite good (Hair, 2010). CR was in the range of 0.62 to 0.75, while the rest did not meet the requirements (Hair, 2010), but the value was still considered acceptable (Fornell & Larcker, 1981). The Average Variance Extracted (AVE) was in the range of 0.35 to 0.51, which meant that a small number of dimensions met the requirements (Hair, 2010); despite this, these results showed the similarity of AVE values from the original instruments developed by Habók and Magyar (2018). Fornell and Larcker (1981) explained that AVE above 0.40 still indicated good strength.

Upon checking the correlation between the five factors of SQRL, it showed that almost all dimensions correlated significantly with each other;  $p < 0.01$ , except for the correlation between dimensions, C and SI. The correlation coefficient on the moderately correlated dimension with the value of  $r$  was in the range of 0.36 to 0.59, indicating that these dimensions were not multicollinear with each other. This concurrent validity check was consistent with the correlations found in CFA with correlated models. These results also showed that the five dimensions identified were correlated, but all five were different dimensions. These five dimensions formed a unity of the main dimension, namely SRQL.

## Students' Self Regulated Qur'an Learning

The average total score was 3.37 in the students' self-regulated Qur'an learning profile (Table 1). This score was slightly higher than the middle point of the five scales. The results of the investigation showed that the SRQL dimensions of students from the highest to the lowest were (1) MA, (2) MSI, (3) C, (4) MC, and (5) SI. The dimensions that had the highest standard deviations were SI and C with 0.80 and 0.80, respectively.

**Figure 1**

*Five-dimension Correlated Model of the SRQL Questionnaire*

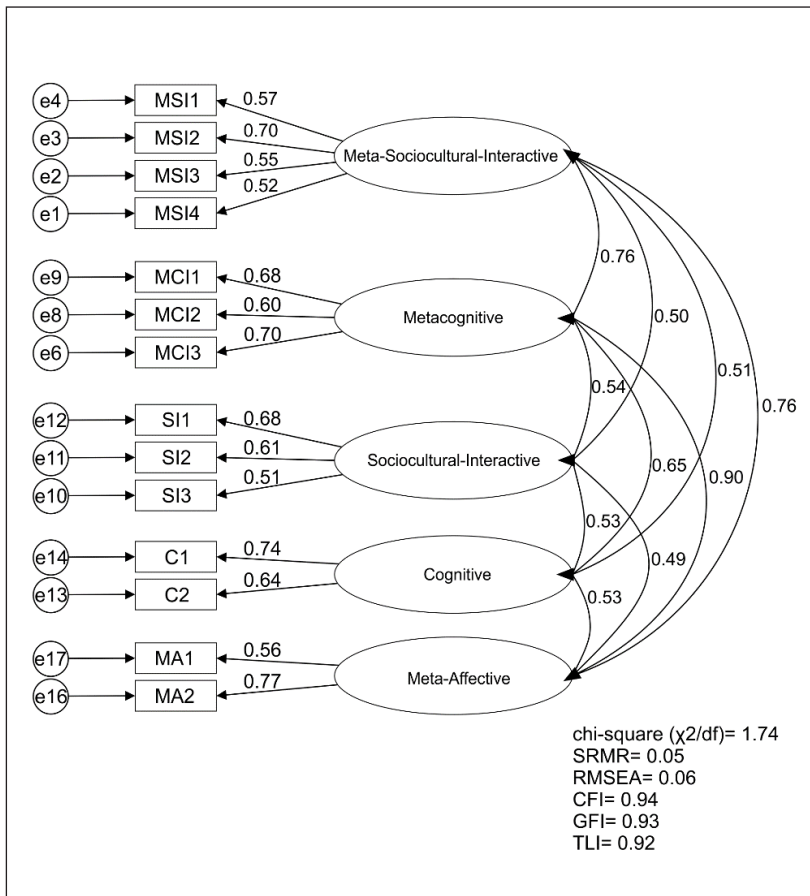

Table 1

*Self-regulated Qur'an Learning (SRQL) Profiles of Students*

Dimension	M	SD	Ranking
Meta Sociocultural Interactive (MSI)	3.49	0.66	MA > MSI > C > MC > SI
Metacognitive (MC)	3.29	0.70	
Sociocultural Interactive (SI)	2.98	0.80	
Cognitive (C)	3.47	0.80	
Meta Affective (MA)	3.64	0.77	

**Qualitative Findings**

During the observations, we found two differences that were quite distinct in the beginning of learning. Students with low SRL seemed less attentive about what their instructor was explaining to the extent of ignoring. Also, they seemed confused when answering some questions raised by the instructor related to Tajweed learning materials during a previous meeting. Based on this situation, interviews on MA and C were focused on students with low SRL.

*Meta-Affective (MA) Interviewer: What do you think of pre-reading activities in the class?*

*Student L1: "I am not too interested in participating in the process of learning Qur'an recitation with techniques like this ... so when the instructor explains about the purpose of today's learning ... I do tend to ignore it but that does not mean that I don't want to learn Qur'an recitation."*

*Interviewer: "So what is the problem with which you are uninterested?"*

*Student L3: "In learning Qur'an recitation at this campus ... students who have low ability are grouped ... maybe not always so. Even I feel that my Quran recitation ability is quite good ... grouping like this makes me feel like a student with quality religion is not good .. to be honest, I feel ashamed because I am still not fluent in recitation of the Qur'an."*

*Cognitive (C) Interviewer: What about your recitation skills?*

*Student L4: "When I am grouped with a group of low-ability students ... then I don't think I need to talk*

*much about recitation skills ... certainly not as good as I should ... I feel confused when the instructor delivers recitation materials not sequentially ... especially at the beginning of learning activities ... I also feel scared when responding incorrectly to questions given by instructors.”*

During our observation of the core learning process, we concluded that generally communication between students and instructors in student groups with low SRL tended to be one-way. Despite this, there were occasional interactions between students. We assumed that the beginning of failed learning resulted in ineffective learning. Clearly, what was problematic in the situation was the low MA and C. In addition, we observed that the instructors did not provide reinforcement and feedback to the students in learning activities. To validate this assumption, we asked a critical question to L3 students:

*Interviewer: Why are you not so active in paired learning sessions?*

*Student L3: “As I said before ... I feel ashamed of my ability which is not good enough for adults ... When I feel something is difficult when reciting verses of the Qur’an then I remain silent ... I am embarrassed if I have to ask ... Maybe my study partner also doesn’t understand my question ... so it’s useless ... The instructor also rarely gives feedback ... whether it’s wrong or right ... we are required to learn independently.”*

Meanwhile, the results of observations of high SRL student groups showed that interactions between them did not always go well. While instructors tended not to do anything, the students interacted and provided assistance to each other. Thus, to explore core activities, interviews regarding SI and MSI were focused on students with high SRL. Previously, we confirmed that they had high enthusiasm for learning and sufficient knowledge of recitation.

*Sociocultural-Interactive (SI) Interviewer: In your opinion, what is the advantage(s) of learning Qur’an recitation in groups?*

*Student H3: “When I am in a group with those who have good Qur’an recitation skills ... I feel benefited ... maybe some of them have higher skills than me ... so when in the process of group learning ... I can get spontaneous correction from friends next to me when mispronouncing.”*

*Student H1: "I agree ... I have a friend who is quite fluent in reciting verses of the Qur'an ... maybe not enough because it's better than me ... I feel lucky to be in a group with him ... I can discuss my problem and he is quite good at explaining it."*

*Meta-Sociocultural-Interactive (MSI) Interviewer: Do you think it's fun to learn by grouping? Do you need learning media?*

*Student H2: "Yes, I feel comfortable learning like this ... sometimes it still feels boring ... but it's still delightful ... it would be better if there were learning media ... and not always the instructor who lectures."*

*Student H4: "I agree ... learning technology in universities is now advanced ... there needs to be a notification ... we can also learn directly from the Internet such as YouTube ... lots of guidance on the recitation of the Qur'an from the Qori."*

For interviews about the MC dimension, we focused on students with high SRL abilities. We assumed that they were good enough in terms of MC abilities so that we could understand how MC played an essential role in the learning of Qur'an recitation.

*Meta-Cognitive (MC) Interviewer: Do you have a unique way to make Qur'an recitation skills better?*

*Student H4: "I have no specific tips ... as usual ... I always relearn what I have learned before ... if in this study ... for example, relearning recitation material."*

*Student H1: "I do Qur'an recitation activities as often as possible ... the more often, the better our skills ... this is the best way, in my opinion."*

*Student H2: "Agree ... I also prove it ... repeated verses that are difficult to pronounce ... will get used to it later."*

## **DISCUSSION AND CONCLUSION**

The dissemination of the questionnaire was intended to adapt and validate SRL instruments in the context of learning Qur'an recitation at universities, especially in Indonesia. Our findings identified 14

item-5 dimensions (Appendix 1) with adequate internal validity, reliability, and consistency. This research succeeded in proving the five dimensions of SRL mentioned by previous scholars (Habók & Magyar, 2018), i.e., MA, MSI, C, MC, and SI, were not only applied in the context of foreign language learning but also applied in learning Qur'an recitation. What should be understood by readers is that we did not equate the Arabic used in the Qur'an with the Arabic in the context of a second language for Indonesian students. We emphasized that learning the recitation of the Qur'an intended in this study was limited to reciting, generally using the shadow reading technique, and not the understanding of meaning, word for word, and verse by verse. This study provided an overview of how SRL students learned to read and pronounce words and verses of the Qur'an. In another sense, we did not equate the word of man with the word of God; this was clearly different. Therefore, we not only adapted the existing questionnaire but also explored and confirmed the dimensions identified in the questionnaire in the context of learning the Qur'an.

This result corresponded to the explanation of Panadero (2017), who contended that SRL encompassed cognitive, metacognitive, behavioural, and affective aspects of learning. Thus, the SRQL questionnaire can be relied upon to record the profile of a student's SRL in a Qur'an recitation learning activity. The SRQL questionnaire used a 5-point Likert scale, from point 1 (*strongly disagree*), to 5 (*strongly agree*). The scores of these items were then added to explain their SRL capacity in learning the Qur'an. The total score of this instrument ranged from 14 to 70, with a higher score indicating a higher level of SRL.

The results of the questionnaire in this study showed that the first-year SRL students were classified as inadequate. This finding was consistent with research conducted by Thibodeaux et al. (2017). Räisänen et al. (2018) also explained that first-year students encountered more stressful situations than students in the next phase because they did not have good SRL. Here, participants received the highest value on the MA dimension ( $M = 3.64$ ) and the lowest value on the SI dimension ( $M = 2.98$ ). What was interesting was that the standard deviation of each dimension was high, reaching > 14 percent of the mean, this meant that there was a large gap between students who had high and low SRL. Each dimension will be discussed in more detail as follows.

**C dimension-** This study confirmed that Tajweed knowledge is necessary and must be applied when learning Qur'an recitation.

The lack of understanding of Tajweed will not affect the quality of reading of the Qur'an, if continually practised (Salic, 2017). Tajweed knowledge and its application is the key to gaining the ability to recite the Qur'an fluently (Ahsiah et al., 2013). Low Tajweed knowledge is a poor start for learning Qur'an recitation. Students must have sufficient understanding of recitation to begin the practice of Qur'an recitation. Moreover, the understanding of initial knowledge by the instructor does not always go well.

**MC dimension-** This study showed that the determination of learning objectives as an initial part of the MC process, has a significant role in determining student learning success. Students with low SRL tended to ignore the learning objectives, and consequently, failed to follow the learning process properly. In the context of Qur'an recitation, MC is also essential for self-control and self-evaluation. Students with low MC do not realize their various mistakes during reading (Garner, 1987). One of the most important findings of the study was that students were not able to determine how to solve problems and correct errors in pronunciation. For instance, by asking for help from friends in a group. Students with high SRL preferred to repeat verses that were considered difficult until they felt that they had mastered them. MC is at the centre of SRL. Winne (1995) defined SRL as an MC process driven towards the development of C strategy. In a model proposed by Winne (2010), SRL is inherently considered as behaviour that is performed in an MC way to deal with various dynamic situations using C strategy. In essence, those who have low MC, have low SRL (Räsänen et al., 2018). This explanation was reinforced from evidence in the study that students with low SRL were not able to employ the MC process from the beginning of the Qur'an recitation learning.

**SI dimension-** In this dimension, the study identified items in learning the Qur'an through technology. The results indicated that technology must be used in learning in higher education to meet current global demands (Andrade, 2014). Students also confirmed that the lack of technology in understanding Qur'an recitation made learning too monotonous because the students only interacted with the instructor. Technology as part of the learning process is an element that can promote SRL (Rajabi, 2012). According to Banyard et al. (2006), technology is not enough to enhance SRL; what is needed is a cultural change, with technology as a vehicle to bring about this change. Web 2.0 technology-in this research is in the form of youtube-provided innovation in learning at universities and is related to support in the

development of SRL (Kitsantas & Dabbagh, 2011). Being able to learn independently and study with peers is an integral part of success in improving SRL through the use of technology (McQuirter Scott & Meeussen, 2017).

**MSI dimension-** In this dimension, the study identified items in learning the Qur'an through technology. The results indicated that technology must be used in learning in higher education to meet current global demands (Andrade, 2014). Students also confirmed that the lack of technology in understanding Qur'an recitation made learning too monotonous because the students only interacted with the instructor. Technology as part of the learning process is an element that can promote SRL (Rajabi, 2012). According to Banyard et al. (2006), technology is not enough to enhance SRL; what is needed is a cultural change, with technology as a vehicle to bring about this change. Web 2.0 technology-in this research is in the form of youtube-provided innovation in learning at universities and is related to support in the development of SRL (Kitsantas & Dabbagh, 2011). Being able to learn independently and study with peers is an integral part of success in improving SRL through the use of technology (McQuirter Scott & Meeussen, 2017).

**MA dimension-** Emotional involvement of students with their environment can enhance the ability of the MA (Uzuntiryaki-Kondakci & Kirbulut, 2016). MA plays a significant role in the process of self-regulation (Mitmansgruber et al., 2009). It makes one aware of the importance of controlling emotions. Every one has a way of managing emotions but tends to change the context (Gross, 2008). As in the findings of this study, most students, especially those with high SRL, tended to change the context by invoking pleasant feelings and supporting their goals and relieving feelings of tension and shame when learning Qur'an recitation. Conversely, students with low SRL experienced stress when they had to relearn Qur'an recitation due to feelings of guilt and tension. The instructor must act as an emotional trainer and create a context marked by classroom interactions and practices that support students in achieving their goals (Corte et al., 2011).

### **Implications, Limitations, and Suggestions**

The findings of this study indicated that the SRQL questionnaire was sufficiently reliable to identify the SRL level of students in learning



the Qur'an. The use of this questionnaire was beneficial to understand the influence of SRL on the learning outcomes of Qur'an recitation. For example, when students are required to attend Qur'an recitation training in their first year at university, instructors can use the SRQL questionnaire to gain an understanding of their student's SRL level. This information will allow instructors to understand how students can overcome problems especially academic anxiety that often occur in learning Qur'an recitation. The instructor will also be able to identify students who need more support, for example, by motivating them to learn so that they can better follow Qur'an learning. Particular attention should be given to students who have low SRL when they initially follow the training of Qur'an recitation. However, the factor structure of the SRQL questionnaire requires further evaluation and validation because the sample used in the two phases of this study was confined to one university. Therefore generalization of the findings of this study cannot be made. The use of the SRQL questionnaire for a wider population, especially in other countries, needs to be confirmed through more stringent psychometric testing. In the future, the SRQL questionnaire also needs to be remodelled by adding different dimensions that could affect the level of SRL in studying the Qur'an, given that experts have put forward many SRL models.

Based on the observations and interviews, students associated low interaction with grouping based on the ability to recite. We suggest a review of this grouping policy. Findings suggest that a homogeneous grouping is very supportive of learning to read (Hallam et al., 2003) because it is tailored to the students' needs (Hallam & Ireson, 2003), especially those with low ability (Nomi, 2009). However, based on this study's findings, the homogeneous grouping had produced adverse effects, as students at the low level felt they had limited opportunities (Boaler et al., 2000). Grouping did not provide significant benefits in reading ability (Matthews et al., 2013). Instead, it presented considerable disadvantages to students who were at the lower levels of SRL (Francis et al., 2017). Thus, the formation of heterogeneous groups is recommended because low ability students are more optimistic about in an inclusive and collaborative learning environment (Tereshchenko et al., 2019). Assuredly, this will have a significant impact on SI students.

In view of the problems in applying SRL in learning Qur'an recitation, in particular the weak collaborative environment or the SI dimension, we would like to suggest some principles for learning Qur'an recitation in SRL. In the initial learning activities, instructors should advise

students to develop a plan to achieve specified learning goals. In addition to helping students activate tajweed knowledge and identify difficulties encountered, instructors must nurture student interest and provide assurance. This effort will help students who are still feeling shy and tensed to start relearning Qur'an recitation. At the core of the activities, the instructor must make students aware of the importance of self-effort as well as help from friends. After giving an outline of what needs to be done during the learning process, instructors must build a conducive environment and support the learning process, allowing students to interact with each other. The formation of heterogeneous groups can create a suitable learning environment structure. Lastly, the instructor can evaluate learning by providing spontaneous response, word for word, in one verse including reasons for mistakes made by students while studying Qur'an recitation.

### ACKNOWLEDGMENT

We are grateful to the Institute of Research and Community Services (IRCS) of Universitas Negeri Malang for funding this study.

### REFERENCES

- Ahsiah, I., Noor, N. M., & Idris, M. Y. I. (2013). Tajweed checking system to support recitation. *2013 International Conference on Advanced Computer Science and Information Systems (ICACSIS)*, 189–193. <https://doi.org/10.1109/ICACSIS.2013.6761574>
- Alvi, E., & Gillies, R. M. (2015). Social interactions that support students' self-regulated learning: A case study of one teacher's experiences. *International Journal of Educational Research*, 72, 14–25. <https://doi.org/10.1016/j.ijer.2015.04.008>
- Alvi, E., & Gillies, R. M. (2020). A case study of a Grade 7 teacher's perspectives and practices related to self-regulated learning (SRL). *Asia-Pacific Journal of Teacher Education*, 48(2), 147–167. <https://doi.org/10.1080/1359866X.2018.1542663>
- Andrade, M. S. (2014). Dialogue and structure: Enabling learner self-regulation in technology-enhanced learning environments. *European Educational Research Journal*, 13(5), 563–574. <https://doi.org/10.2304/eej.2014.13.5.563>
- Banyard, P., Underwood, J., & Twiner, A. (2006). Do enhanced communication technologies inhibit or facilitate self-regulated learning? *European Journal of Education*, 41(3–4), 473–489. <https://doi.org/10.1111/j.1465-3435.2006.00277.x>

- Boaler, J., Wiliam, D., & Brown, M. (2000). Students' experiences of ability grouping—Disaffection, polarisation and the construction of failure. *British Educational Research Journal*, 26(5), 631–648. <https://doi.org/10.1080/713651583>
- Boekaerts, M. (1997). Self-regulated learning: A new concept embraced by researchers, policymakers, educators, teachers, and students. *Learning and Instruction*, 7(2), 161–186. [https://doi.org/10.1016/S0959-4752\(96\)00015-1](https://doi.org/10.1016/S0959-4752(96)00015-1)
- Boekaerts, M. (1999). Self-regulated learning: Where we are today. *International Journal of Educational Research*, 31, 445–457.
- Boud, D., Cohen, R., & Sampson, J. (Eds.). (2001). *Peer learning in higher education: Learning from & with each other*. Stylus Pub.
- Brislin, R. W. (1970). Back-translation for cross-cultural research: *Journal of Cross-Cultural Psychology*. <https://doi.org/10.1177/135910457000100301>
- Cha, E.-S., Kim, K. H., & Erlen, J. A. (2007). Translation of scales in cross-cultural research: Issues and techniques. *Journal of Advanced Nursing*, 58(4), 386–395. <https://doi.org/10.1111/j.1365-2648.2007.04242.x>
- Christie, H., Barron, P., & D'Annunzio-Green, N. (2013). Direct entrants in transition: Becoming independent learners. *Studies in Higher Education*, 38(4), 623–637. <https://doi.org/10.1080/03075079.2011.588326>
- Corte, E., Depaepe, F., Op 't Eynde, P., & Verschaffel, L. (2011). Students' self-regulation of emotions in mathematics: An analysis of meta-emotional knowledge and skills. *ZDM*, 43(4), 483–495. <https://doi.org/10.1007/s11858-011-0333-6>
- Dörnyei, Z. (2003). *Questionnaires in second language research: Construction, administration, and processing*. Lawrence Erlbaum Associates.
- Fornell, C., & Larcker, D. F. (1981). Evaluating structural equation models with unobservable variables and measurement error. *Journal of Marketing Research*, 18(1), 39–50. <https://doi.org/10.2307/3151312>
- Francis, B., Archer, L., Hodgen, J., Pepper, D., Taylor, B., & Travers, M.-C. (2017). Exploring the relative lack of research on 'ability grouping' in England: A discourse analytic account. *Cambridge Journal of Education*, 47(1), 1–17. <https://doi.org/10.1080/0305764X.2015.1093095>
- Garner, R. (1987). *Metacognition and reading comprehension*. Ablex Publishing.

- Gross, J. J. (2008). Emotion regulation. In *Handbook of emotions* 3rd ed. (pp. 497–512). The Guilford Press.
- Habók, A., & Magyar, A. (2018). Validation of a self-regulated foreign language learning strategy questionnaire through multidimensional modelling. *Frontiers in Psychology*, 9(1388), 1–11. <https://doi.org/10.3389/fpsyg.2018.01388>
- Hadwin, A. F., Järvelä, S., & Miller, M. (2011). Self-regulated, co-regulated, and socially shared regulation of learning. In *Handbook of self-regulation of learning and performance* (pp. 65–84). Routledge/Taylor & Francis Group.
- Hadwin, A. F., Järvelä, S., & Miller, M. (2018). Self-regulation, co-regulation and shared regulation in collaborative learning environments. In D. Schunk & J. Greene (Eds.), *Handbook of Self-Regulation of Learning and Performance* (2nd ed.). Routledge, Taylor & Francis Group.
- Hair, J. F. (Ed.). (2010). *Multivariate data analysis* (7th ed.). Pearson Prentice Hall.
- Hallam, S., & Ireson, J. (2003). Secondary school teachers' attitudes and beliefs about ability grouping. *British Journal of Educational Psychology*, 73, 343–356.
- Hallam, S., Ireson, J., Lister, V., Chaudhury, I. A., & Davies, J. (2003). Ability grouping practices in the primary school: A survey. *Educational Studies*, 29(1), 69–83. <https://doi.org/10.1080/03055690303268>
- Hanafi, Y., Murtadho, N., Hassan, A. R., Ikhsan, M. A., & Diyana, T. N. (2019). Development and validation of a questionnaire for teacher effective communication in Qur'an learning. *British Journal of Religious Education*, 1–11. <https://doi.org/10.1080/01416200.2019.1705761>
- Hanafi, Y., Murtadho, N., Ikhsan, M. A., & Diyana, T. N. (2020). Reinforcing public university student's worship education by developing and implementing mobile-learning management system in the ADDIE instructional design model. *International Journal of Interactive Mobile Technologies (iJIM)*, 14(2), 215. <https://doi.org/10.3991/ijim.v14i02.11380>
- Hanafi, Y., Murtadho, N., Ikhsan, M. A., Diyana, T. N., & Sultoni, A. (2019). Student's and instructor's perception of the effectiveness of E-BBQ enhances Al-Qur'an reading ability. *International Journal of Instruction*, 12(3), 51–68. <https://doi.org/10.29333/iji.2019.1234a>
- Harding, S.-M., English, N., Nibali, N., Griffin, P., Graham, L., Alom, B., & Zhang, Z. (2019). Self-regulated learning as a predictor of mathematics and reading performance: A picture of students in Grades 5 to 8. *Australian Journal of Education*, 63(1), 74–97. <https://doi.org/10.1177/0004944119830153>

- Huie, F. C., Winsler, A., & Kitsantas, A. (2014). Employment and first-year college achievement: The role of self-regulation and motivation. *Journal of Education and Work, 27*(1), 110–135. <https://doi.org/10.1080/13639080.2012.718746>
- Kaiser, H. F. (1970). A second generation little jiffy. *Psychometrika, 35*(4), 401–415. <https://doi.org/10.1007/BF02291817>
- Kitsantas, A., & Dabbagh, N. (2011). The role of Web 2.0 technologies in self-regulated learning. *New Directions for Teaching and Learning, 2011*(126), 99–106. <https://doi.org/10.1002/tl.448>
- Kline, P. (1994). *An easy guide to factor analysis*. Routledge.
- Knouse, L. E., Feldman, G., & Blevins, E. J. (2014). Executive functioning difficulties as predictors of academic performance: Examining the role of grade goals. *Learning and Individual Differences, 36*, 19–26. <https://doi.org/10.1016/j.lindif.2014.07.001>
- Koivuniemi, M., Panadero, E., Malmberg, J., & Järvelä, S. (2017). Higher education students' learning challenges and regulatory skills in different learning situations / Desafíos de aprendizaje y habilidades de regulación en distintas situaciones de aprendizaje en estudiantes de educación superior. *Journal for the Study of Education and Development / Infancia y Aprendizaje, 40*(1), 19–55. <https://doi.org/10.1080/02103702.2016.1272874>
- Korstjens, I., & Moser, A. (2018). Series: Practical guidance to qualitative research. Part 4: Trustworthiness and publishing. *European Journal of General Practice, 24*(1), 120–124. <https://doi.org/10.1080/13814788.2017.1375092>
- Laidlaw, A., McLellan, J., & Ozakinci, G. (2016). Understanding undergraduate student perceptions of mental health, mental well-being and help-seeking behaviour. *Studies in Higher Education, 41*(12), 2156–2168. <https://doi.org/10.1080/03075079.2015.1026890>
- Lindblom-Ylänne, S., Haarala-Muhonen, A., Postareff, L., & Hailikari, T. (2017). Exploration of individual study paths of successful first-year students: An interview study. *European Journal of Psychology of Education, 32*(4), 687–701. <https://doi.org/10.1007/s10212-016-0315-8>
- Liu, H. H.-T., & Lee, Y.-S. (2015). Measuring self-regulation in second language learning: A Rasch analysis. *SAGE Open, 5*(3), 1–12. <https://doi.org/10.1177/2158244015601717>
- Mason, L. H. (2004). Explicit self-regulated strategy development versus reciprocal questioning: Effects on expository reading comprehension among struggling readers. *Journal of Educational Psychology, 96*(2), 283–296. <https://doi.org/10.1037/0022-0663.96.2.283>

- Matthews, M. S., Ritchotte, J. A., & McBee, M. T. (2013). Effects of schoolwide cluster grouping and within-class ability grouping on elementary school students' academic achievement growth. *High Ability Studies*, 24(2), 81–97. <https://doi.org/10.1080/13598139.2013.846251>
- McQuirter Scott, R., & Meeussen, N. (2017). Self-regulated learning: A touchstone for technology-enhanced classrooms. *The Reading Teacher*, 70(6), 659–666. <https://doi.org/10.1002/trtr.1564>
- McWhaw, K., & Abrami, P. C. (2001). Student goal orientation and interest: Effects on students' use of self-regulated learning strategies. *Contemporary Educational Psychology*, 26(3), 311–329. <https://doi.org/10.1006/ceps.2000.1054>
- Mitmansgruber, H., Beck, T. N., Höfer, S., & Schübler, G. (2009). When you don't like what you feel: Experiential avoidance, mindfulness and meta-emotion in emotion regulation. *Personality and Individual Differences*, 46(4), 448–453. <https://doi.org/10.1016/j.paid.2008.11.013>
- Morshedian, M., Hemmati, F., & Sotoudehnama, E. (2017). Training EFL Learners in self-regulation of reading: Implementing an SRL model. *Reading & Writing Quarterly*, 33(3), 290–303. <https://doi.org/10.1080/10573569.2016.1213147>
- Nomi, T. (2009). The effects of within-class ability grouping on academic achievement in early elementary years. *Journal of Research on Educational Effectiveness*, 3(1), 56–92. <https://doi.org/10.1080/19345740903277601>
- Oi, M., Yin, C., Okubo, F., Shimada, A., Kojima, K., Yamada, M., & Ogata, H. (2015). Analysis of Links among E-books in undergraduates' E-Book logs. In H. Ogata (Ed.), *Proceedings of the 23rd International Conference on Computers in Education*. (pp. 665–669). Asia-Pacific Society for Computers in Education.
- Panadero, E. (2017). A Review of self-regulated learning: Six Models and Four directions for Research. *Frontiers in Psychology*, 8(422), 1–28. <https://doi.org/10.3389/fpsyg.2017.00422>
- Pape, S. J., Bell, C. V., & Yetkin, İE. (2003). Developing mathematical thinking and self-regulated learning: A teaching experiment in a seventh-grade mathematics classroom. *Educational Studies in Mathematics*, 53(3), 179–202. <https://doi.org/10.1023/A:1026062121857>
- Peng, C. (2012). Self-regulated learning behavior of college students of science and their academic achievement. *Physics Procedia*, 33, 1446–1450. <https://doi.org/10.1016/j.phpro.2012.05.236>

- Pintrich, P. (2000). The role of goal orientation in self-regulated learning. *Handbook of Self-Regulation*. <https://doi.org/10.1016/B978-012109890-2/50043-3>
- Pintrich, P. R. (1999). The role of motivation in promoting and sustaining self-regulated learning. *International Journal of Educational Research*, 31(6), 459–470. [https://doi.org/10.1016/S0883-0355\(99\)00015-4](https://doi.org/10.1016/S0883-0355(99)00015-4)
- Pintrich, P. R., & de Groot, E. V. (1990). Motivational and self-regulated learning components of classroom academic performance. *Journal of Educational Psychology*, 82(1), 33–40. <https://doi.org/10.1037/0022-0663.82.1.33>
- Räsänen, M., Postareff, L., Mattsson, M., & Lindblom-Ylänne, S. (2018). Study-related exhaustion: First-year students' use of self-regulation of learning and peer learning and perceived value of peer support. *Active Learning in Higher Education*, 1–16. <https://doi.org/10.1177/1469787418798517>
- Rajabi, S. (2012). Towards self-regulated learning in school curriculum. *Procedia - Social and Behavioral Sciences*, 47, 344–350. <https://doi.org/10.1016/j.sbspro.2012.06.661>
- Salic, J. Z. (2017). Difficulties of reading the Holy Qur'an as perceived by selected Muslim male faculty members in MSU-Main: Bases of intervention program. *Journal of Social Sciences (COES&RJ-JSS)*, 6(2S), 27–33. <https://doi.org/10.25255/jss.2017.6.2S.27.33>
- Schunk, D. H. (1989). Social cognitive theory and self-regulated learning. In B. J. Zimmerman & D. H. Schunk (Eds.), *Self-Regulated Learning and Academic Achievement: Theory, Research, and Practice* (pp. 83–110). Springer. [https://doi.org/10.1007/978-1-4612-3618-4\\_4](https://doi.org/10.1007/978-1-4612-3618-4_4)
- Tabachnick, B. G., & Fidell, L. S. (2007). *Using multivariate statistics* (5th ed.). Allyn & Bacon/Pearson.
- Tereshchenko, A., Francis, B., Archer, L., Hodgen, J., Mazonod, A., Taylor, B., Pepper, D., & Travers, M.-C. (2019). Learners' attitudes to mixed-attainment grouping: Examining the views of students of high, middle and low attainment. *Research Papers in Education*, 34(4), 425–444. <https://doi.org/10.1080/02671522.2018.1452962>
- Thibodeaux, J., Deutsch, A., Kitsantas, A., & Winsler, A. (2017). First-Year college students' time use: Relations with self-regulation and GPA. *Journal of Advanced Academics*, 28(1), 5–27. <https://doi.org/10.1177/1932202X16676860>
- Usher, E. L., & Schunk, D. H. (2018). The social-cognitive theoretical perspective of self-regulation. In J. A. Greene & D. H. Schunk (Eds.), *Handbook of Self-Regulation of Learning and Performance* (2nd ed.). Routledge, Taylor & Francis Group.



- Uzuntiryaki-Kondakci, E., & Kirbulut, Z. D. (2016). The development of the meta-affective trait. *Psychology in the Schools*, 53(4), 359–374. <https://doi.org/10.1002/pits.21910>
- Winne, P. H. (1995). Inherent details in self-regulated learning. *Educational Psychologist*, 30(4), 173–187. [https://doi.org/10.1207/s15326985ep3004\\_2](https://doi.org/10.1207/s15326985ep3004_2)
- Winne, P. H. (2010). Improving measurements of self-regulated learning. *Educational Psychologist*, 45(4), 267–276. <https://doi.org/10.1080/00461520.2010.517150>
- Zarif, M. M. M., Mohamad, N., & Bakar, B. A. (2014). Assessing Quranic reading proficiency in the j-QAF programme. *International Education Studies*, 7(6), p 1. <https://doi.org/10.5539/ies.v7n6p1>
- Zimmerman, B. J. (2000). Attaining self-regulation. In *Handbook of Self-Regulation*, 13–39. Elsevier. <https://doi.org/10.1016/B978-012109890-2/50031-7>
- Zimmerman, B. J., Bandura, A., & Martinez-Pons, M. (1992). Self-motivation for academic attainment: The role of self-efficacy beliefs and personal goal setting. *American Educational Research Journal*, 29(3), 663–676. <https://doi.org/10.3102/00028312029003663>



## Appendix 1

### Self-Regulated Learning in Quranic Recitation Questionnaire

Dimension	Item Description
Meta-sociocultural-interactive (MSI)	<p>How do you control and manage their interactions with others including learning resources as a strategy for learning Qur'an recitation?</p> <ul style="list-style-type: none"><li>○ I am looking for someone fluent in reading the Qur'an to teach me recitation of the Qur'an.</li><li>○ I practise recitation of the Qur'an with my friends.</li><li>○ I watch TV or YouTube shows to get to know how Qori (the reader of the Qur'an) recites the verses of the Qur'an fluently.</li><li>○ I am looking for similarities and differences between Qori (Qur'anic reader) and me in reciting verses of the Qur'an either directly or through the help of YouTube.</li></ul>
Sociocultural-interactive (SI)	<p>How do you interact with others to teach them Qur'an recitation?</p> <ul style="list-style-type: none"><li>○ I learn by asking friends to listen to my reading and justify if there are mistakes.</li><li>○ I always discuss my difficulties in learning Qur'an recitation with friends.</li><li>○ When I have the opportunity to study with people who are fluent in reciting the Qur'an, I always ask them how to recite verses from the Qur'an.</li></ul>
Metacognitive (MC)	<p>How do you construct their knowledge and improve their reading ability?</p> <ul style="list-style-type: none"><li>○ I learn recitation of the Qur'an by reading through the verses of the Qur'an first, and then rereading it carefully.</li><li>○ I keep trying to find out how to become a better learner in the recitation of the Qur'an.</li><li>○ I plan my schedule between my busy times so that I would have enough time to learn Qur'an recitation.</li></ul>

Cognitive (C)	How do you apply Tajweed knowledge (Qur'an recitation rules) to improve the quality of their reading?
	<ul style="list-style-type: none"><li>○ I understand recitation and always use it when learning Qur'an recitation.</li> <li>○ I always try to read the new Surah Qur'an that I have memorized in prayer according to the rules of tajweed so that I can continue to improve the quality of my reading.</li></ul>
Meta-Affective (MA)	How do you realize and manage their feelings so that they remain positive and enthusiastic about learning Qur'an recitation?
	<ul style="list-style-type: none"><li>○ I try to calm down whenever I feel afraid of being wrong while learning recitation of the Qur'an.</li> <li>○ Even though I felt ashamed, I tried to stay calm while studying the Qur'an as an adult.</li></ul>

---